

# Allegro V-mount (homemade versions)

M.Drela 01.12.01

Design loads: 10 lb on bolt  
10 oz on horn

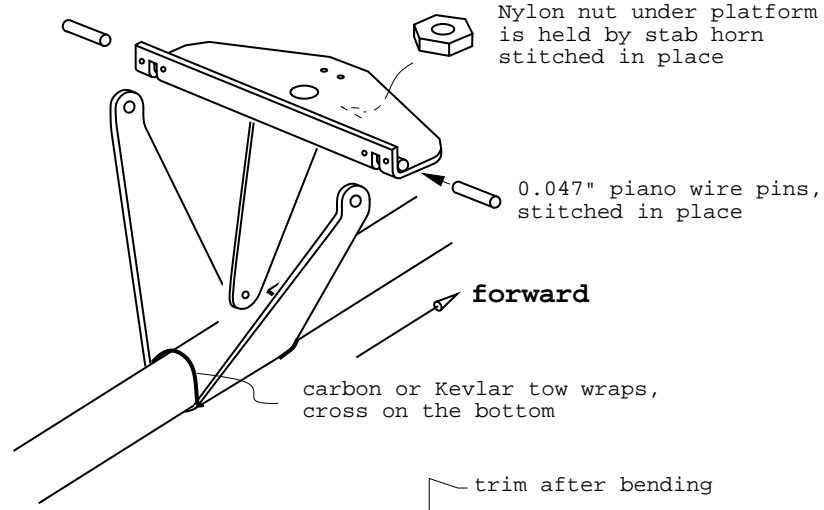

## Aluminum Version (2.5g)

(Full size patterns)

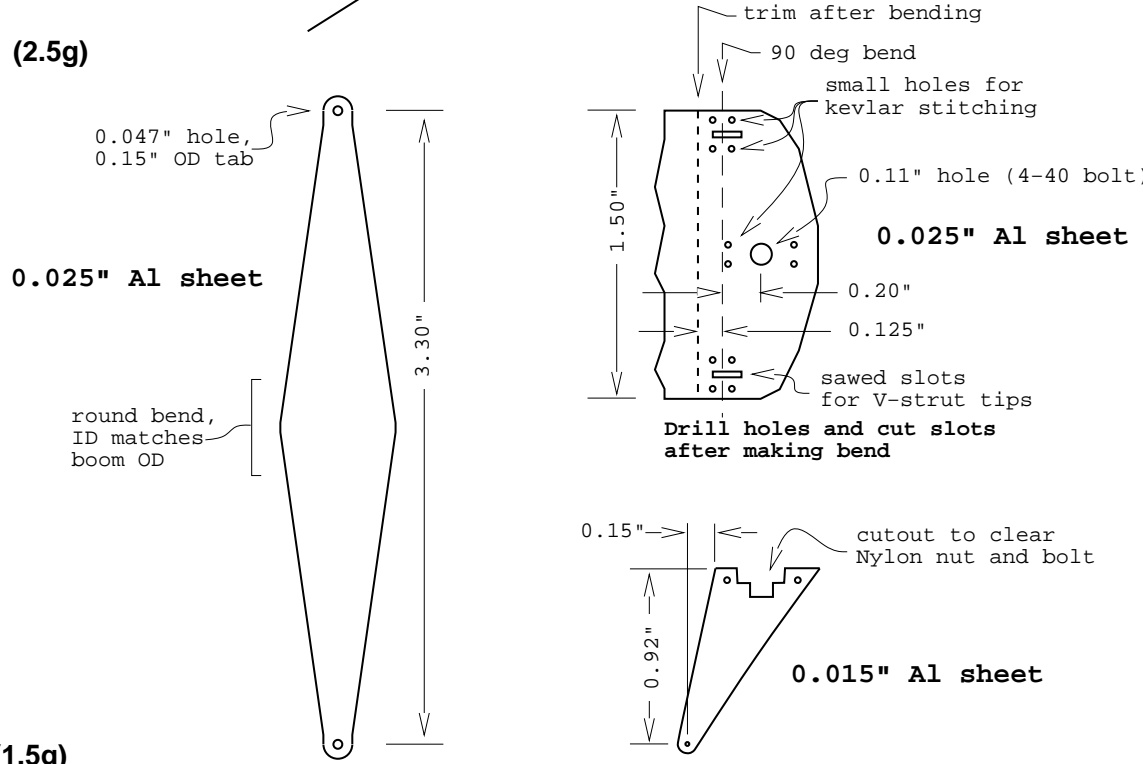

## Carbon Version (1.5g)

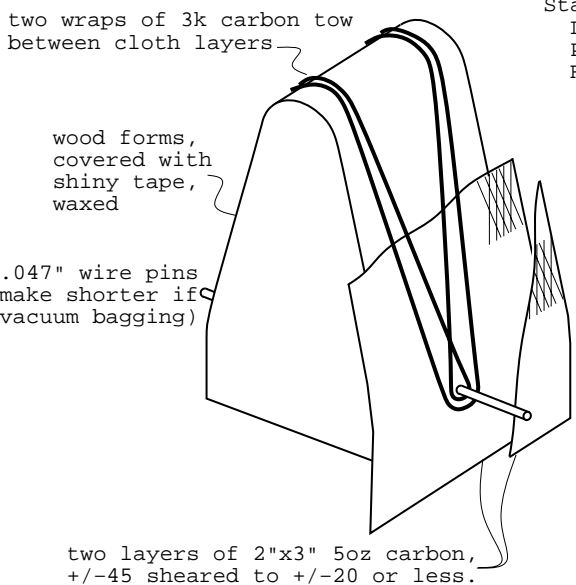

Stab horn...  
Laminated from two layers 5 oz carbon, +/-20.  
Poke with wire to form pushrod hole (better than drilling).  
Roughen and attach to platform with 0.75oz glass fillets while platform epoxy is still green (see below)

